

LAMP® FD35EV SLIDING DOOR SYSTEM Installation Manual Part No. FD35EV-HRP2 FD35EV-HRP3

Recessed Mount Roller, Multiple Synchronized Sliding Door, Two-Way Soft Close

Thank you for using our product. Before installation, please read this manual thoroughly to ensure correct installation. Please keep this manual at hand for future reference.

ABOUT THE PRODUCT

- This product is a parts set for an indoor synchronized sliding door system with two-way soft motion in opening and closing directions.
- This is a parts set for a sliding door system for residential & commercial use.

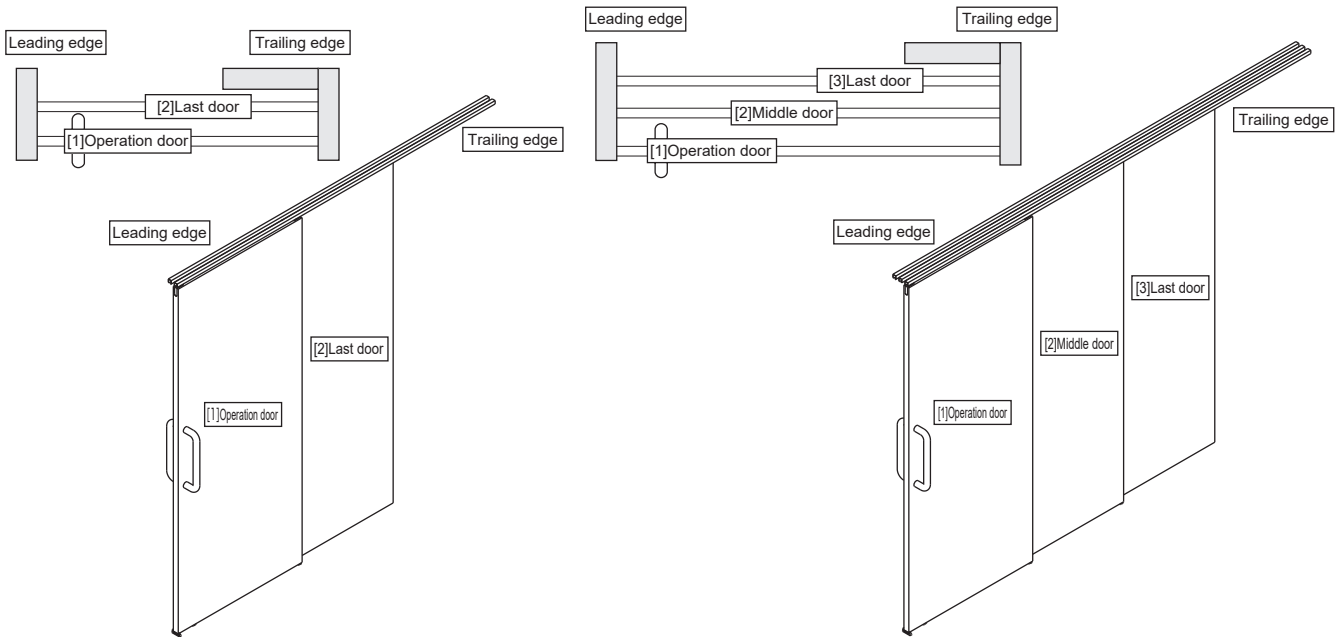

FOR YOUR SAFE WORK AND CORRECT INSTALLATION

Meaning of symbols



WARNING: If not followed, death or serious injury may result.







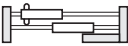

- ❗ This (sliding door system) should be installed by a qualified person. If the system is not installed correctly, the door will not operate smoothly, and may cause injury.
- ❗ It is necessary to manufacture the frame with sufficient strength so that it endures the weight of the door and any impact upon opening/closing the door. Only use designated screws and ensure that they are fastened firmly. A frame with poor strength or loose screws might result in the door falling and causing injury.
- ⊘ Do not try to use this product for anything other than its original purpose. Do not use any part for applications outside of its specification.
- ⊘ Do not disassemble nor modify any parts other than those described in this document.

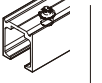
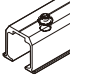
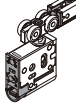
Caution: If not followed injury or damage may result.

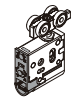
- ❗ Make sure to follow the designated dimensions, specifications, and horizontal/vertical angles. Make sure that the frame is not warped, since it may affect the movement of the door.
- ❗ If cutting any parts, make sure to remove any burrs before installation. Also check the upper track for any left-over burrs or scraps and remove these.
- ❗ This product is a part for architectural fittings. After installation, make sure to test the finished product thoroughly to ensure that it is well-functioning and safe. Please inform the end user about general precautions and safety to prevent improper use.
- ❗ Make sure to check the screws for slack at regular intervals (one month from first usage, half a year, and then one time every year is recommended).

COMPONENT PARTS(2 doors synchronized)

	Available opening width (RO) When margin DN = 0	Door width	Max. Door height (DH)	Door thickness (Dt)	Max. Door weight	Vertical adjustment	Right-and-left adjustment
	1020 - 1840 mm	590 - 1000 mm	2400 mm	30 - 38 mm	35 kg	- 3 - +4 mm	± 2 mm

No.	①	②	③	④	⑤	⑥	⑦	⑧	⑨	⑩	
Name	Upper track (surface mount)	Upper track (recessed mounted)	Soft closer (two-way)	Trigger	Upper roller	Trigger	Door guide (door mount)	Door guide (wall mount)	Block for bottom guide	Bumper block	Door guide track
Item No.	FD35EV-TRM-SC	FD35EV-TRH-SC	FD35EV-WRH-DSC	FD35EV-TRG	FD35EV-WRH-N	FD35EV-TRG	FD30-HRDG	FD30-HBGF	FD30-HRDB	FD35EV-HBB	FD30-HBRT1500SIL
Item	 Use 2 (surface mounted or recessed) Hole pitch : 300 mm Pitch end : 30 mm										
Accessories	-	Flat head tapping screws 3.8 X 40...3 pcs	Countersunk head tapping screws 4 X 30...2 pcs	Flat head tapping screws 3.8 X 40...3 pcs	Countersunk head tapping screws 4 X 30...2 pcs	Countersunk head tapping screws 4 X 25...5 pcs	Countersunk head tapping screws 4 X 25...4 pcs	Countersunk head tapping screws 4 X 25...4 pcs	Truss head tapping screw 3.5 X 30...1pc	-	-
Remarks	Countersunk head tapping screws 3.5 X 25 (Qty depends on the hole location)	-	Included in ②	-	-	-	-	-	-	-	Recommended screw: Countersunk head tapping screw 4 X 20

INSTALLATION DRAWING

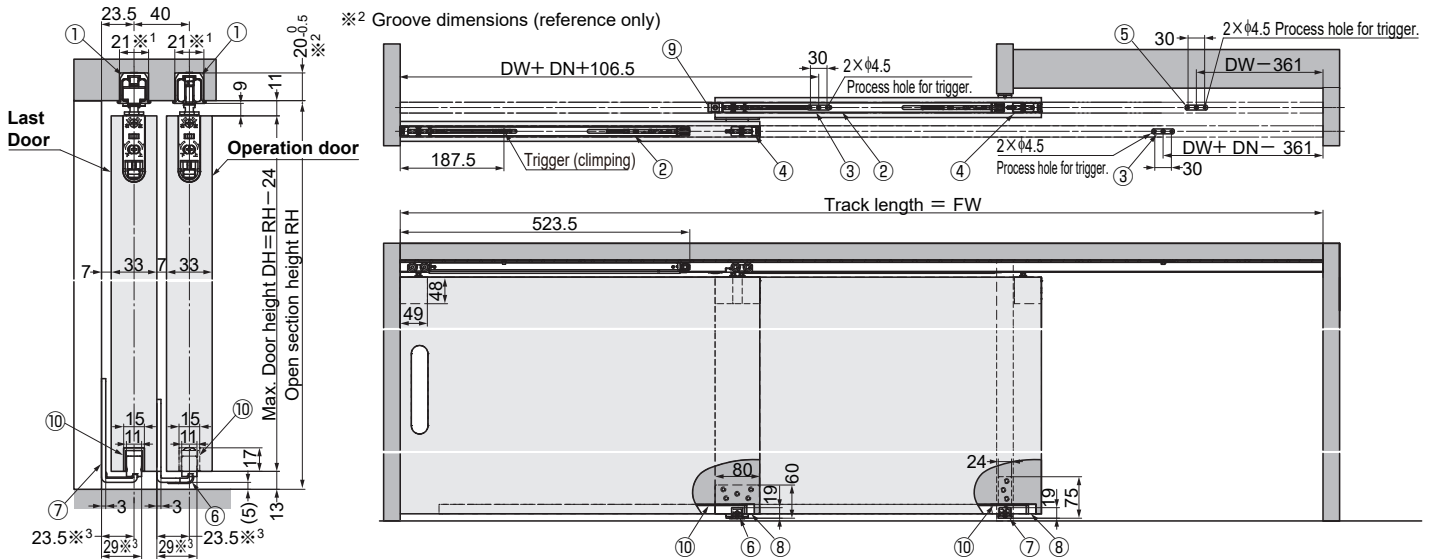

In case of 33 mm thick door
(recessed mounted track)

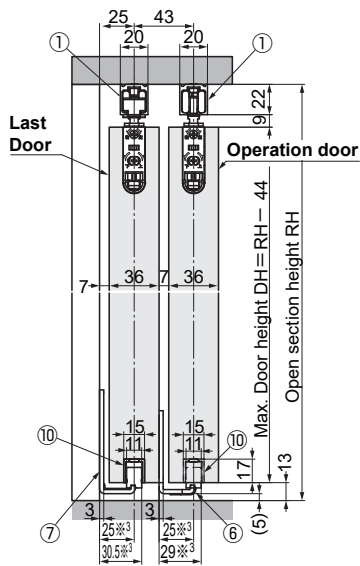

In case of 36 mm thick door
(surface mounted track)

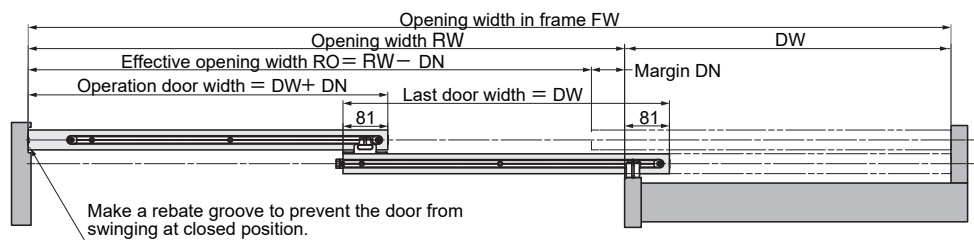

- ※1 The groove depth 21 is for reference only.
- ※2 The dimension is for reference only.
- ※3 The door guides ⑥ & ⑦ are adaptable by changing the direction of the head part.

Door process dimensions [] : When cover cap (option) is used.

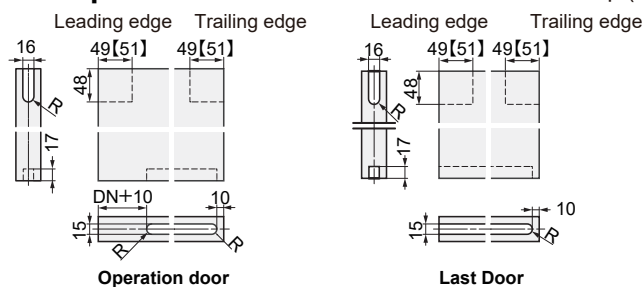

COMPONENT PARTS(3 doors synchronized)

	Available opening width (RO) When margin DN = 0	Door width	Max. Door height (DH)	Door thickness (Dt)	Max. Door weight	Vertical adjustment	Right-and-left adjustment
	1530 - 2760 mm	590 - 1000 mm	2400 mm	30 - 38 mm	35 kg	- 3 - +4 mm	± 2 mm

No.	①	②	③	④	⑤	⑥	⑦	⑧	⑨	⑩	
Name	Upper track (surface mount)	Upper track (recessed mounted)	Soft closer (two-way)	Trigger	Upper roller	Trigger	Door guide (door mount)	Door guide (wall mount)	Block for bottom guide	Bumper block	Door guide track
Item No.	FD35EV-TRM-SC	FD35EV-TRH-SC	FD35EV-WRH-DSC	FD35EV-TRG	FD35EV-WRH-N	FD35EV-TRG	FD30-HRDG	FD30-HBGF	FD30-HRDB	FD35EV-HBB	FD30-HBRT1500SIL
Item	 Use 3 (surface mounted or recessed) Hole pitch : 300 mm Pitch end : 30 mm		 3 pcs	 3 pcs	 3 pcs	 2 pcs	 2 pcs	 1 pc	 5 pcs	 2 pcs	 3 pcs
Accessories	-	Flat head tapping screws 3.8 x 40...3 pcs	Countersunk head tapping screws 4 x 30...2 pcs	Flat head tapping screws 3.8 x 40...3 pcs	Countersunk head tapping screws 4 x 30...2 pcs	Countersunk head tapping screws 4 x 25...5 pcs	Countersunk head tapping screws 4 x 25...4 pcs	Truss head tapping screw 3.5 x 30...1pc	-	-	-
Remarks	Countersunk head tapping screws 3.5 x 25 (Qty depends on the hole location)	-	Included in ②	-	-	-	-	-	-	-	Recommended screw: Countersunk head tapping screw 4 x 20

INSTALLATION DRAWING

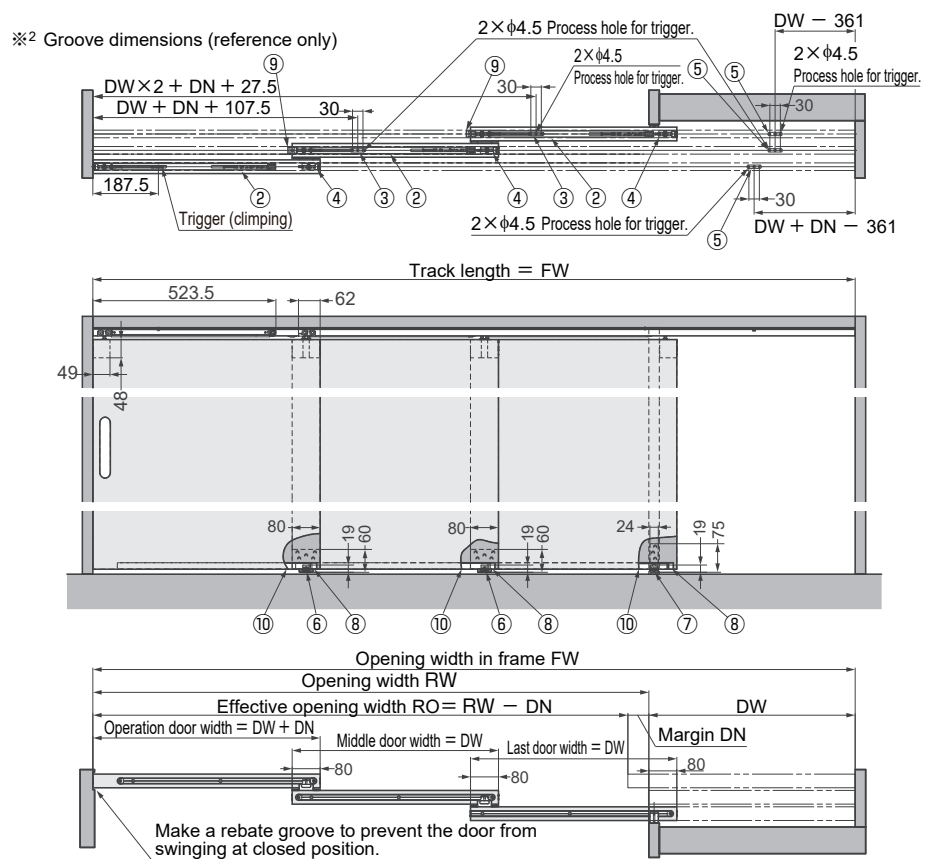
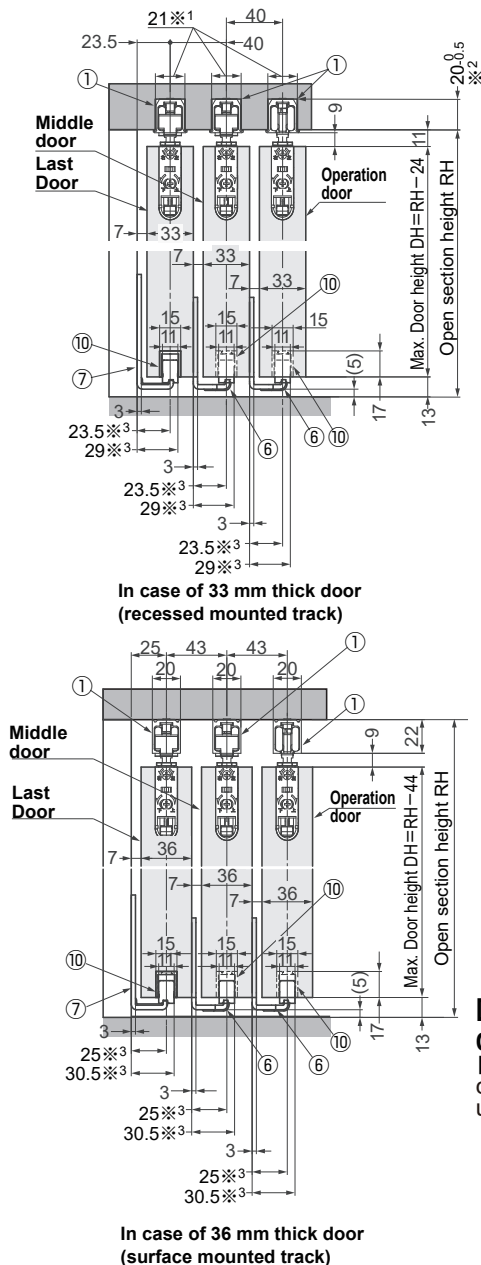

- ※1 The groove depth 21 is for reference only.
- ※2 The dimension is for reference only.
- ※3 The door guides ⑥ & ⑦ are adaptable by changing the direction of the head part.

Door process dimensions

[] : When cover cap (option) is used.

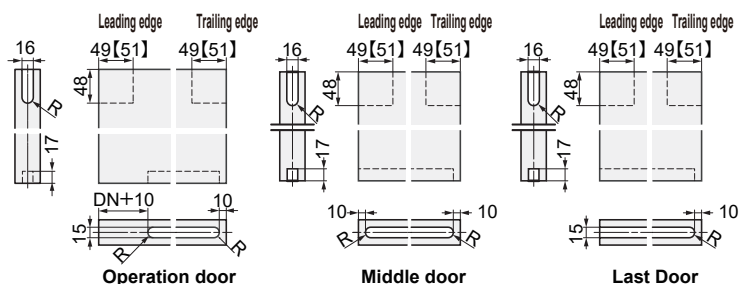

INSTALLATION PROCEDURE

1 Cutting and Providing Hole on Upper Track

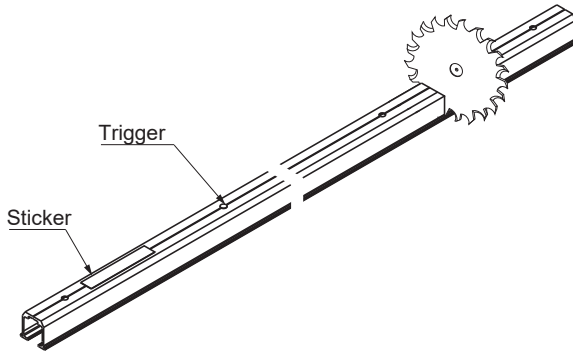

⚠ Caution

⊘ Do not cut trigger side (with sticker) of upper track.

⚠ Caution

❗ When cutting, reinforce the track to prevent deformation at the cut section.

2 Hole Processing on Tracks

⟨2 doors synchronized⟩

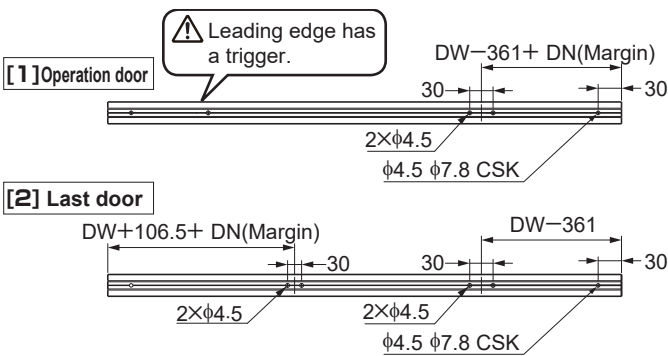

⟨3 doors synchronized⟩

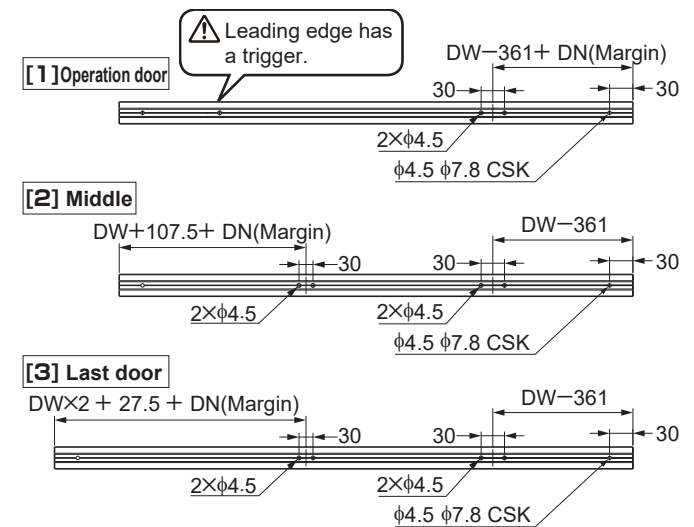

3 Mounting Parts on Door

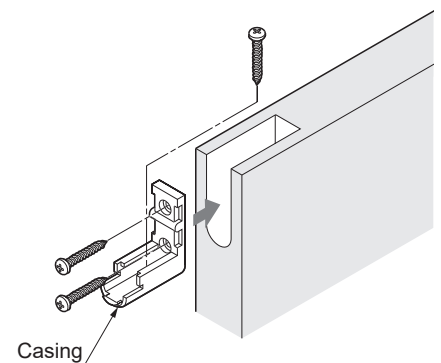
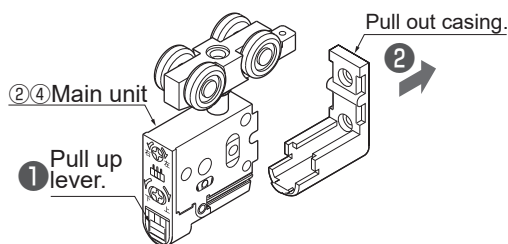

4 Assembly of Door Guide

Turn the direction of the guide block according to door thickness.

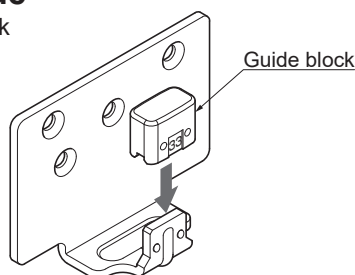

Door thickness	Marking
30 - 34	33
35 - 38	36

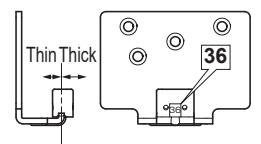
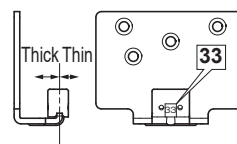

5 Parts Assembly on Doors △ For an opposite handed door, assemble the parts in the mirror opposite position.

<2 doors synchronized>

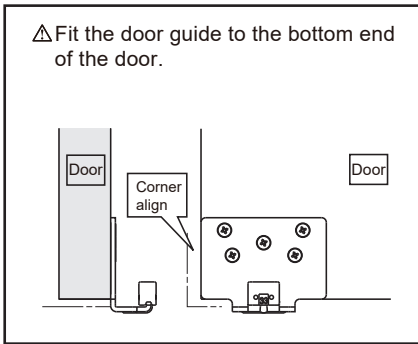
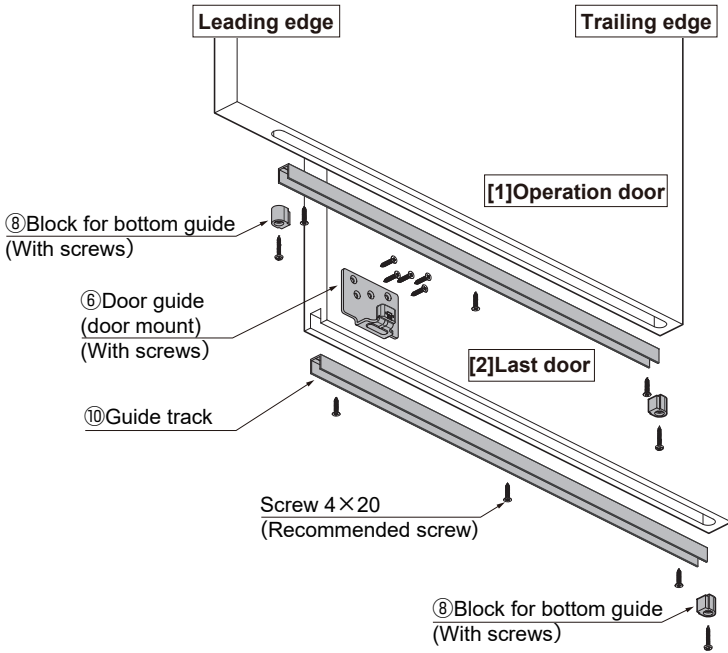

<3 doors synchronized>

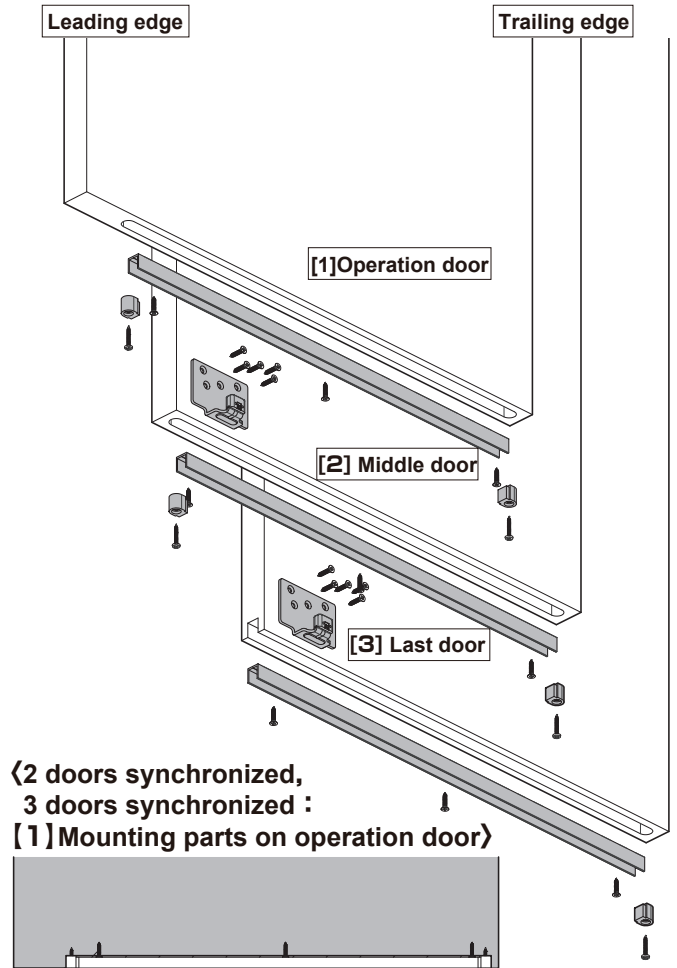

<2 doors synchronized, 3 doors synchronized : [1] Mounting parts on operation door>



Guide track length of operation door = DW-50-DN (Margin)

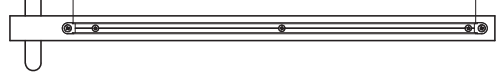

<2 doors: Mounting parts on last door>

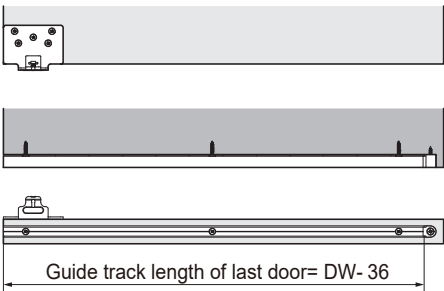

<3 doors: Mounting parts on middle door>

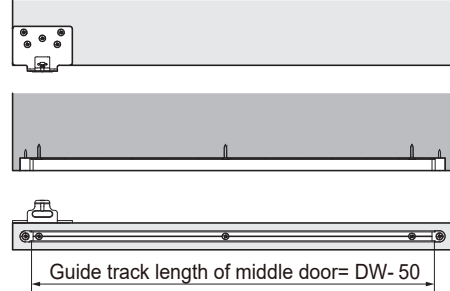

<3 doors: Mounting parts on last door>

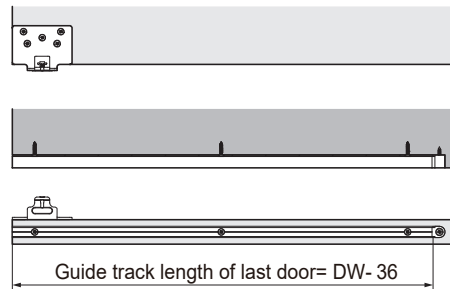

6 Verification Before Installing Soft Closer

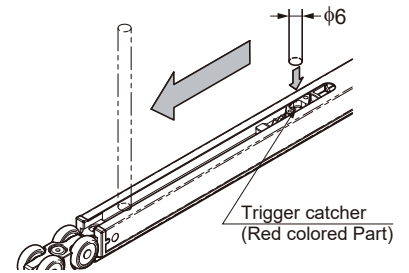
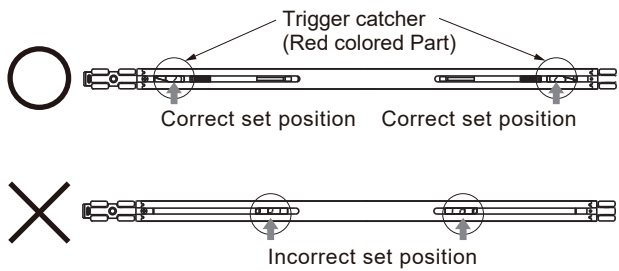

If the position is wrong, pull back the trigger catcher to the correct position using a 6mm diameter hard bar.

Caution

Without verification the self closing feature may fail.

7 Assembly of Upper Tracks

Insert the parts in the same order as shown in the figure. Tape around rollers and upper track to prevent inserted parts from falling.

⚠ Remove any dirt or aluminum chips from the track.

⚠ Please prepare the screws; Countersunk head tapping screw 3.5× 25)

(2 doors synchronized)

(3 doors synchronized)

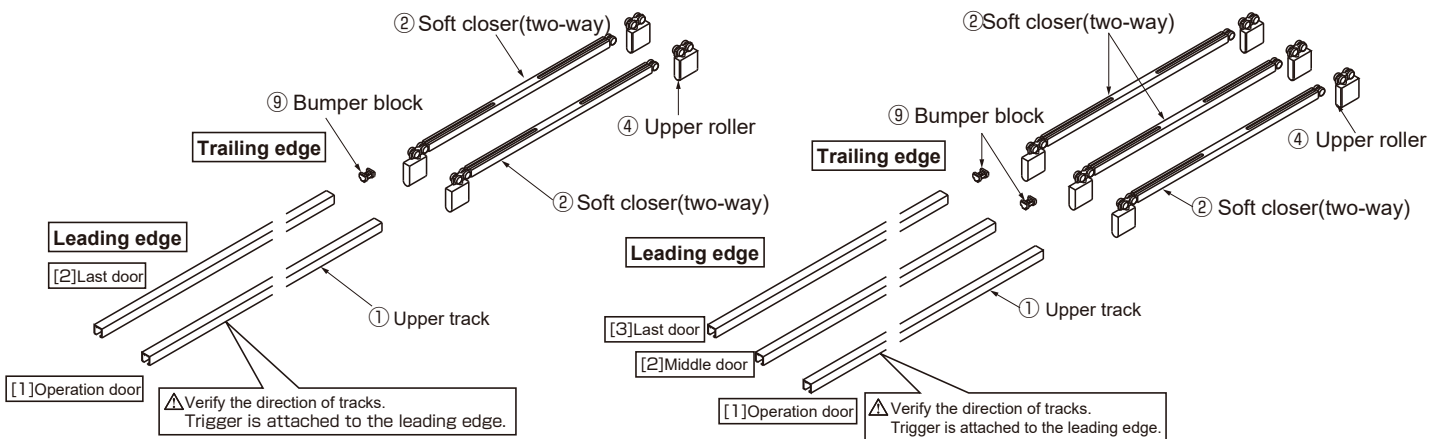

8 Fastening Additional Triggers

Fix trigger to the hole made during procedure 2.

(2 doors synchronized)

(2 doors synchronized)

(3 doors synchronized)

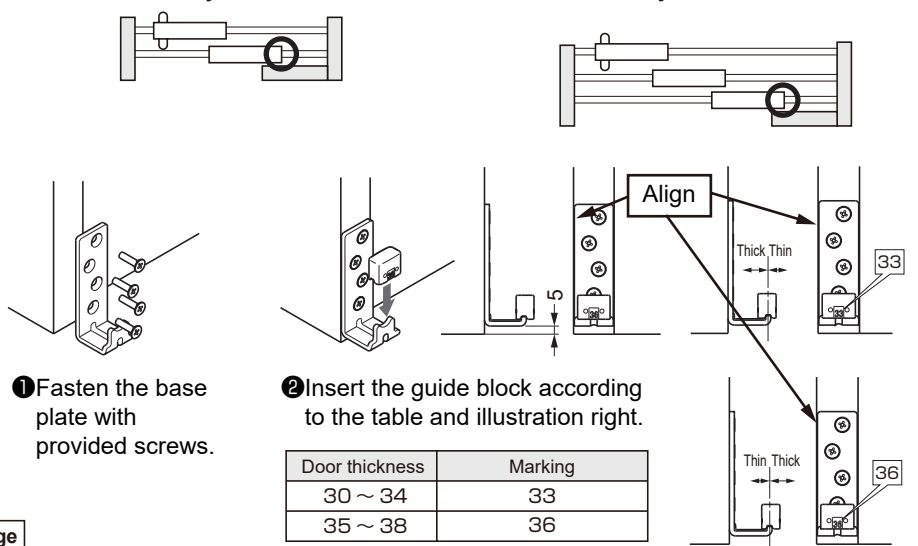
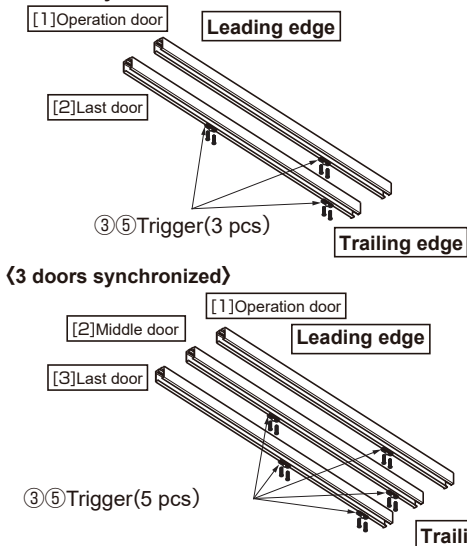

10 Hanging Door

- [1] Order of hanging
Hang the doors in order from ① to ③.
- [2] Hanging
Put a 13 mm support under the door.
While holding the door, insert the guide into the groove under the door.

- [3] Insert the upper roller into the casing until a click sound is heard.
Verify that the main unit is not dislocated from the casing, for both door head and door tail sides.

<2 doors synchronized>

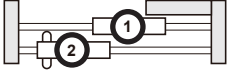

<3 doors synchronized>

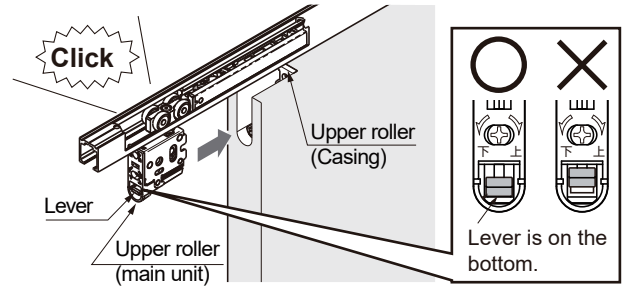
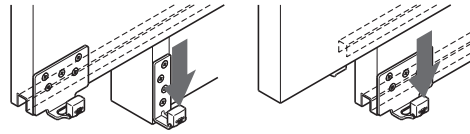
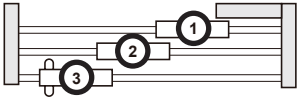

11 Verification of Sliding Door Closer Operation

- [1] Remove the 13 mm support from under the door.
- [2] Close the door slowly and check that the soft closer works correctly.
- [3] For the operation door, carry out similar verification for the door trailing edge.
- [4] Please refer to the "Troubleshooting" if the soft closer does not work correctly.
- [5] If necessary, adjust position of bumper block in the track so that the position is realized as shown in "Installation Drawing". Then fix them by tightening them with screws.

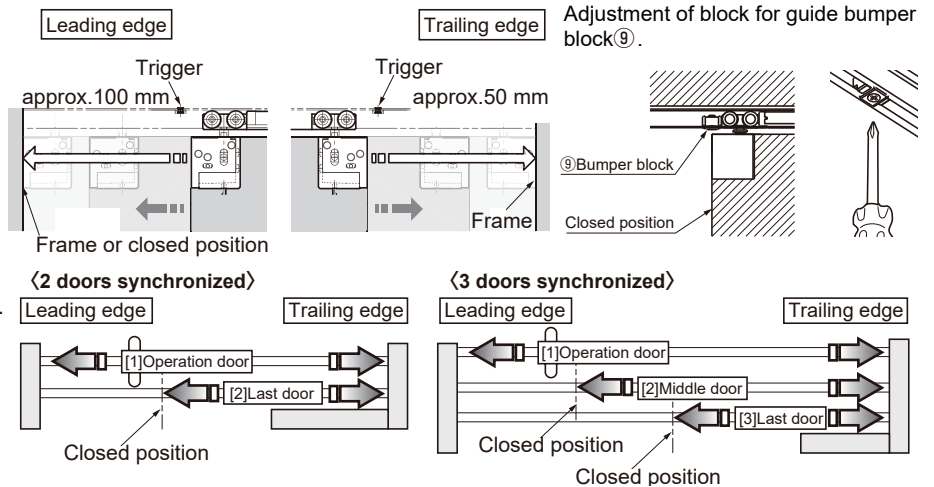

12 Adjusting Door Position

- [1] Order: [1] Operation door, [2] Middle door, [3] Last door
- [2] [1]: Adjust the door so that it is parallel to the upper track with 6-13 mm of clearance between the door and floor.
- [3] [2], [3]: Adjust the door so that the clearance between the door bottom and door guide will be 5 mm.

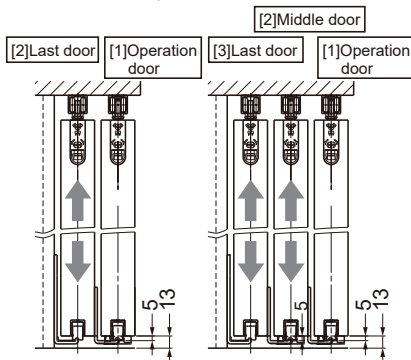

- ⚠ The adjustment of the door should be done with the jump prevention nut loosened (see section 13).
- ⊘ Do not turn adjustment screw beyond adjustment range.
- ⊘ Do not use electric screw driver.

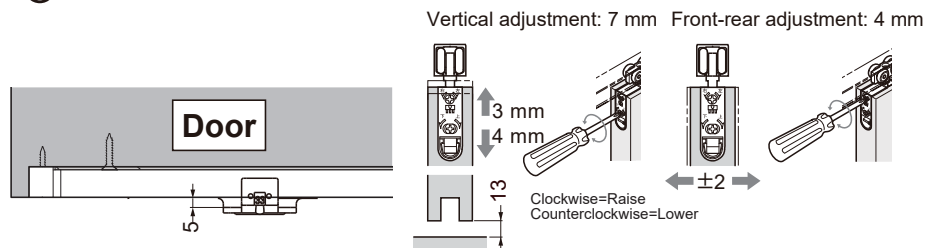

After finishing vertical adjustment of door, repeat confirmation of sliding door closer operation (section 11).
If the door is not closed completely, the clearance between the door bottom and door guide may be less than 5 mm. In this case, lower the middle door and the last door slightly.

13 Fastening the Jump Prevention Nut

The jump prevention nut is on the hanger bolt of the recessed roller. Tighten the nut until it comes into contact with the soft closer.

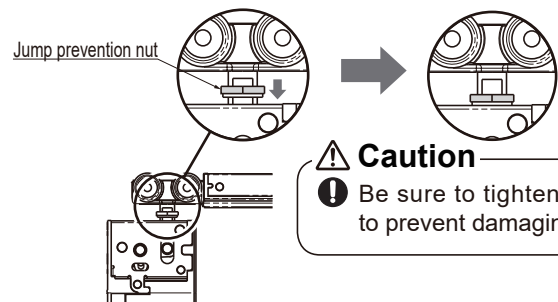
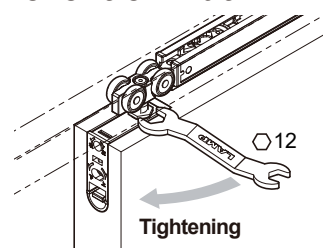

Supplement How to Remove Door

Use a 13 mm support under the door.
Then pull out the upper roller main unit from the door while raising the lever(※⁴).
It will be easier if you slide the hanger bolt with a spanner.

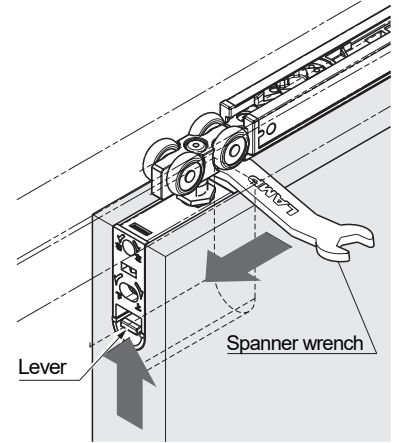

Caution

Be careful not to let the door fall.

PERIODICAL INSPECTION

- Clean inside of track.
- Check upper and lower gaps between the door and frame. If necessary, adjust the gaps.

TROUBLESHOOTING

Trouble	Check Point	Solution
Door stops during soft closing	Check if door bottom contacts the floor or floor guide.	Verify that the track mounting screws are not loosened. Then, adjust the door height such that the clearance between the door bottom and floor is 6 - B mm.
	Check if upper track is set horizontally.	Using a level gauge, reset upper track horizontally.
	Check if mohair seal is installed.	Reduce the friction between mohair and door.
No soft closing	Check if trigger is installed.	Install trigger to correct position.
	Check if door is closed by excessive force.	Do not close door by excessive force as it may damage soft closer.
	The position of the trigger catcher in page 6 section 6 may become dislocated. (It is hidden as installed in upper track.)	Slowly move the door towards the leading edge, then push the door firmly. Repeat this action on the opposite side as well. If it is still not improved, check the status of the trigger catcher in section 6.
Abnormal noise during operation	Check if door touches adjacent parts.	Adjust the door depth position to avoid contact with other objects or adjust the position of floor guide.
	Check track rollers for aluminum dust.	Remove the track, then pull out and clean the roller.
	Check the track mounting screws for looseness.	Retighten the screws to free the roller.
Heavy door operation	Check if door touches adjacent parts.	Adjust the door depth position to avoid contact with other objects or adjust the position of floor guide.
Door does not move.	Check the track retaining screws for looseness.	Retighten screws to free the roller.

SUGATSUNE KOGYO CO., LTD.
Tokyo, JAPAN
Phone: +81 3 3866 2260
E-mail: export@sugatsune.co.jp

SUGATSUNE KOGYO (UK) LIMITED
Reading, UK
Phone: +44 1189 272 955
E-mail: sales@sugatsune.co.uk

SUGATSUNE EUROPE GmbH
Düsseldorf, GERMANY
Phone: +49 211 53812 900
E-mail: sales@sugatsune.eu

SUGATSUNE AMERICA, INC.
California, USA
Phone: +1 310 329 6373
E-mail: sales@sugatsune.com

Chicago, USA
Phone: +1 630 317 7072
E-mail: sales@sugatsune.com

SUGATSUNE CANADA, INC.
Montreal, CANADA
Phone: +1 514 312 5267
E-mail: support@sugatsune.ca

SUGATSUNE SHANGHAI CO., LTD.
Shanghai, CHINA
Phone: +86 21 3632 1858
E-mail: lamp@sugatsune.com.cn

Guangzhou, CHINA
Phone: +86 20 6639 3554
E-mail: lamp@sugatsune.com.cn

SUGATSUNE KOREA CO., LTD.
Incheon, KOREA
Phone: +82 32 220 0603
E-mail: sales@sugatsune-korea.co.kr

SUGATSUNE KOGYO INDIA PRIVATE LIMITED
Mumbai, INDIA
Phone: +91 9867299597
E-mail: sales@sugatsune.in
Delhi, INDIA
Phone: +91 9867299597
+91 11 45093636
E-mail: sales@sugatsune.in