

# Installation Manual

## FD30SP, FD50SP SLIDING DOOR SYSTEM Recessed Mount Roller, Multiple Synchronized Sliding Door, Two-Way Soft Close

**LAMP®**

Part No.  
FD30SP-HRP2  
FD30SP-HRP3  
FD50SP-HRP2  
FD50SP-HRP3

Thank you for using our product. Before installation, please read this manual thoroughly to ensure correct installation.  
Please keep this manual at hand for future reference.

### ABOUT THE PRODUCT

- This product is a parts set for an indoor synchronized sliding door system with two-way soft motion in opening and closing directions.
- Top-hung sliding door hardware for indoor use.

#### 2 doors synchronized

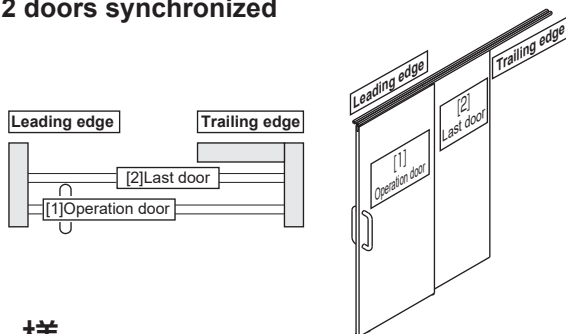

#### 3 doors synchronized

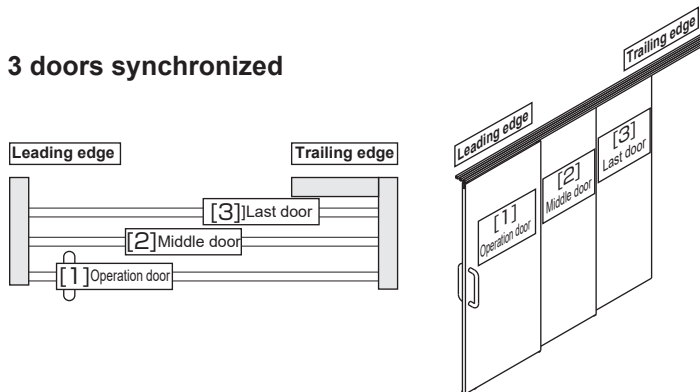

### 仕様

	Effective open width (RO)	Door width	Middle door width	Last door width	Max. Door height (DH)	Door thickness (Dt)	Max. Door weight	Vertical adjustment	Front-rear adjustment
FD30SP 2 doors synchronized	1020-1840 mm with no margin (DN)	590-1000 mm	510-1000 mm	510	2400 mm	30 - 38mm	30 kg	± 3 mm	± 2 mm
	940-1760 mm with 80 mm of margin (DN)			-1000 mm					
FD30SP 3 doors synchronized	1530-2760 mm with no margin (DN)	590-1000 mm	510-1000 mm	510	2400 mm	30 - 38mm	30 kg	± 3 mm	± 2 mm
	1290-2680 mm with 80 mm of margin (DN)								
FD50SP 2 doors synchronized	1200-2240 mm with no margin (DN)	680-1200 mm	680-1200 mm	680	2400 mm	30 - 38mm	50 kg	± 4 mm	± 2 mm
	1120-2160 mm with 80 mm of margin (DN)								
FD50SP 3 doors synchronized	1800-3360 mm with no margin (DN)	680-1200 mm	680-1200 mm	680	2400 mm	30 - 38mm	50 kg	± 4 mm	± 2 mm
	1720-3280 mm with 80 mm of margin (DN)								

### FOR YOUR SAFETY AND CORRECT INSTALLATION

**Warning Caution**   **Prohibited**   **Required**

#### WARNING: If not followed, death or serious injury may result.



- This product should be installed by a qualified person in accordance with this manual. If it is not installed correctly, the door may fall and cause injury.
- Provide a frame that can withstand the weight and impact of opening and closing the door. Be sure to use the specified screws and tighten them securely. If the mounting strength is insufficient, the door may fall and cause injury.



- Do not use this product for any other purpose, or with doors that are outside the specifications of this manual.
- Do not disassemble or modify any parts other than those described in this document.

#### Caution: If not followed, injury or damage may result.



- Follow the specified dimensions, specifications, and alignment of the door and frame. Warping, tilting or twisting of the frame or door may cause failure.
- If cutting any parts, make sure to remove any burrs before installation. Also check the upper track for any left-over burrs or scraps and remove these.
- This product is a part for architectural fittings. After installation, please check the function and safety of the final product. Please inform the end user how to use the product safely.
- Make sure to check the screws for slack at regular intervals (one month from first usage, half a year, and then one time every year is recommended).
- Install the product with two people (in the case of one person, there is a risk of damaging components).

# COMPONENT PARTS (FD30SP)

No.	①	②	③	④	⑤	⑥	⑦	⑧	⑨	⑩
Name	End stopper	Door guide (door mount)	Door guide (wall mount)	Block for bottom guide	Guide track	Bumper block	Soft closer (two-way)*1	Soft closer (one-way)	Upper roller	Trigger *1
Item No.	FD30-HRGU	FD30-HRDG	FD30-HBGF	FD30-HRDB	FD30-HBDR1000	FD30-HBB	FD30SP-WRH-DSC	FD30SP-WRH-SC	FD30SP-WRH-N	Included in ⑦
Item										
2 doors synchronized	L/R 1 ea	1 pc	1 pc	1 pc	2 pcs	1 pc	1 pc	1 pc	2 pcs	2 pcs / 1 pc
3 doors synchronized	L/R 2 ea	2 pcs	1 pc	1 pc	3 pcs	2 pcs	1 pc	2 pcs	3 pcs	3 pcs / 1 pc

No.	⑪	
Name	Upper track (surface mount)	Upper track (recessed mounted)
Item No.	FD30-TRM	FD30-TRH
Item		
	1820mm - 4000mm Hole pitch : 300 Pitch end : 30mm Recommended screw : Countersunk head tapping screws 3.5×20	
2 doors synchronized	Use 2 (surface mounted or recessed)	
3 doors synchronized	Use 3 (surface mounted or recessed)	

No.	⑫	⑬	⑭	⑮
Name	Cover cap	Door stopper (floor)	Floor guide	Bottom guide
Item No.	FDSP-WRH-CP	FD30-HTKY	FD30-HBG	FD30-HTF
Item				
		Bind head tapping screw 4×30...3 pcs	Countersunk head tapping screw 3.5×30...4 pcs	Countersunk head tapping screw 3.5×25...2 pcs

⑯	
Accessory	Spanner wrench
	FDSP-SP

## INSTALLATION DRAWING (EXAMPLE: FD30SP)

### 2 doors synchronized

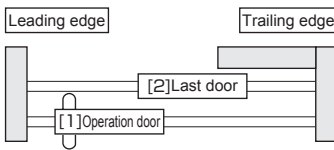

\*1 The dimension varies with the assembled direction of the guide block on the door guide ②③ (see section 9).

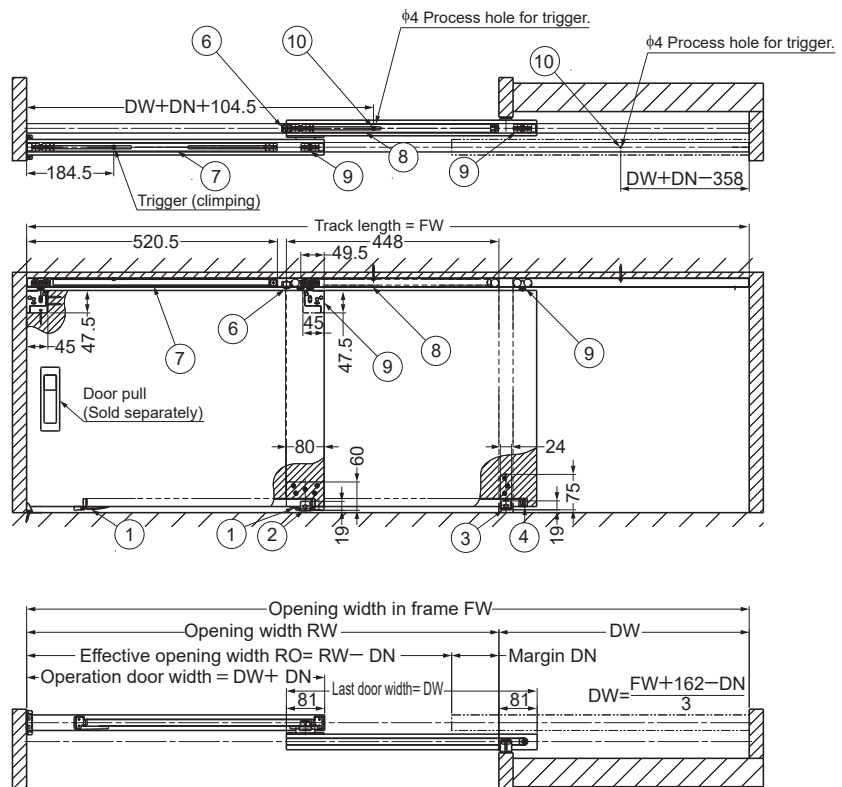
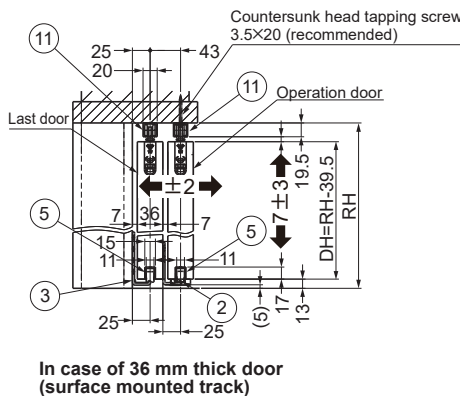
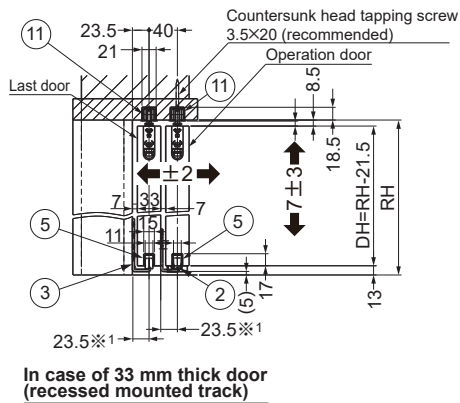





### 3 doors synchronized

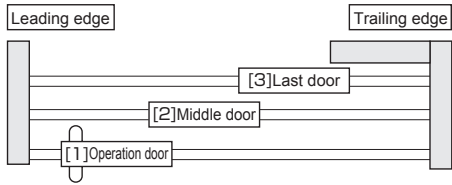

※1 The dimension varies with the assembled direction of the guide block on the door guide  
②③ (see section 9).

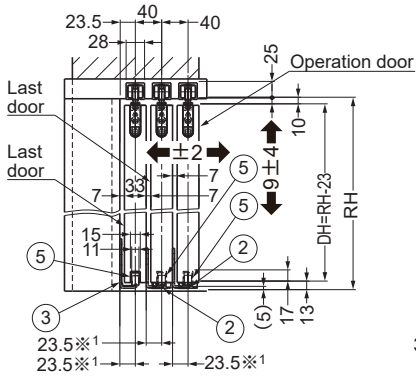

In case of 33 mm thick door (recessed mounted track)

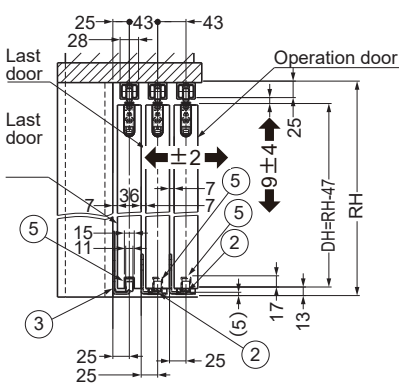

In case of 36 mm thick door (surface mounted track)

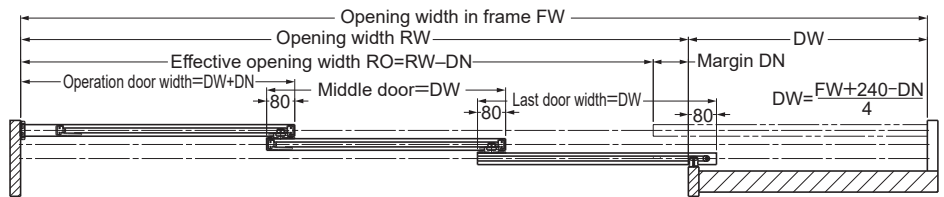
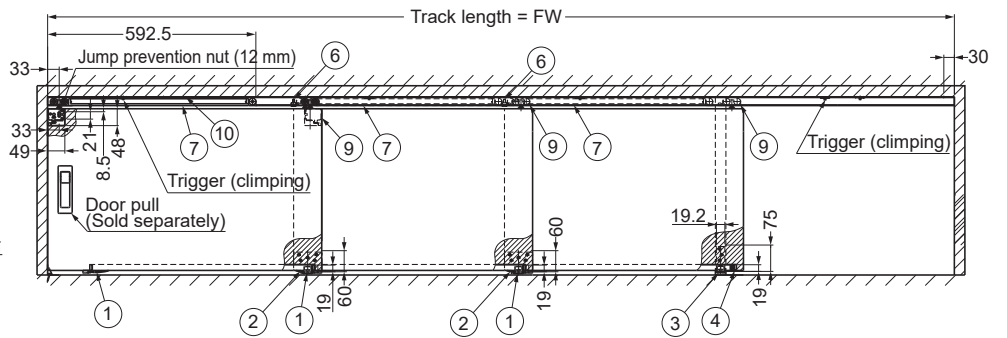
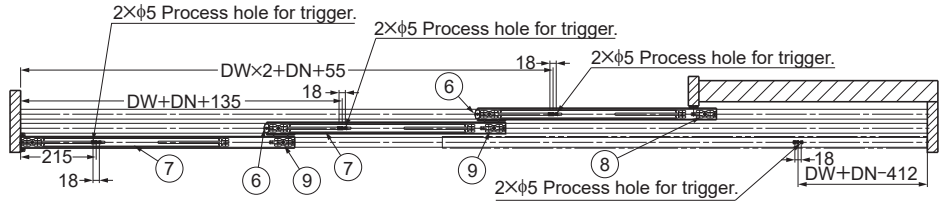

## DOOR PROCESS DIMENSIONS (FD50)

### Operation door, Middle door

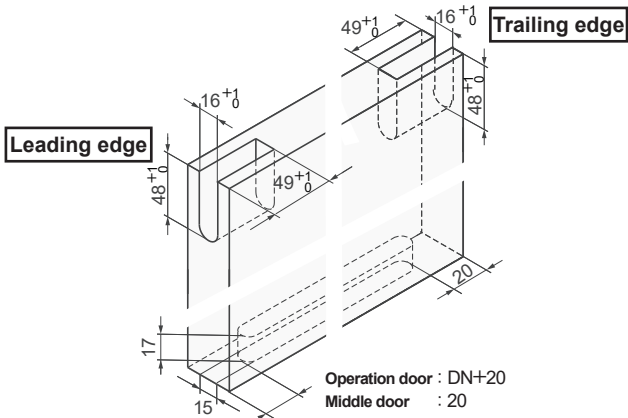

Operation door : DN+20  
Middle door : 20

### Last door

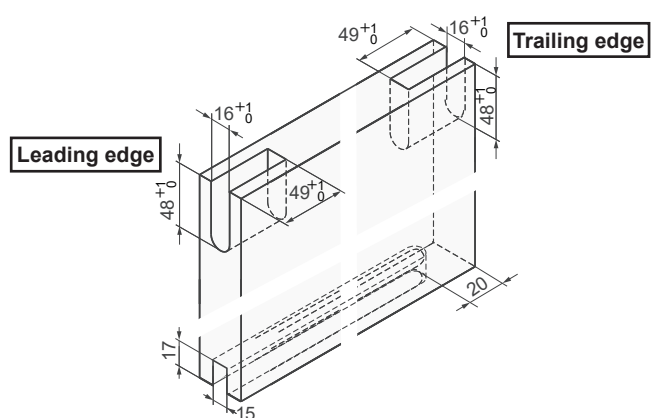

### When using cover cap

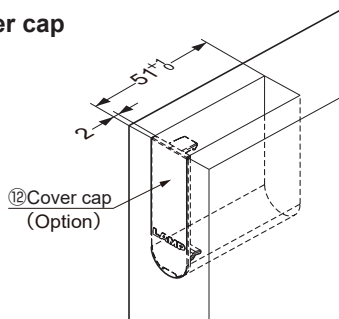

### When using cover cap

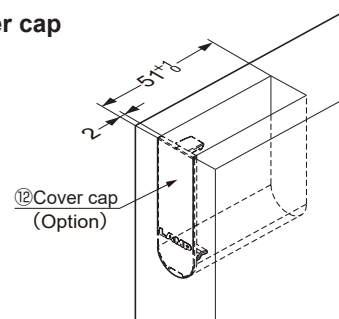

# ASSEMBLY

## 1 Cutting and Providing Hole on Upper Track

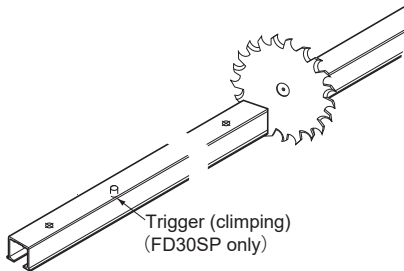

**Caution**

- When cutting, reinforce the track to prevent deformation at the cut section.
- Remove any dirt or aluminum chips from the track.

**Caution**

- For FD30SP, do not cut the track on the side with trigger.

## 2 Hole Processing on Tracks

### <FD30SP: 2 doors synchronized>

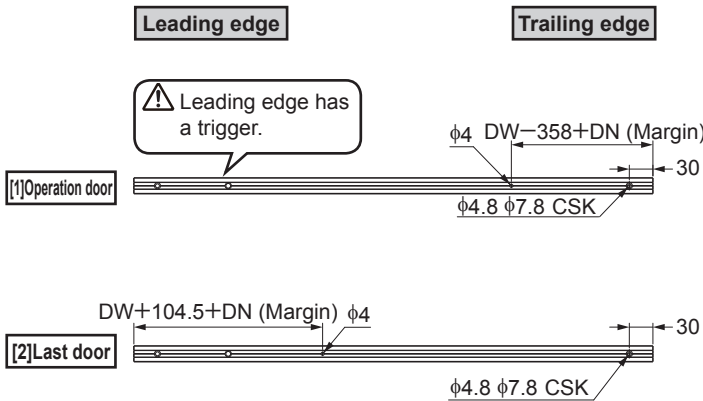

### <FD50SP: 2 doors synchronized>

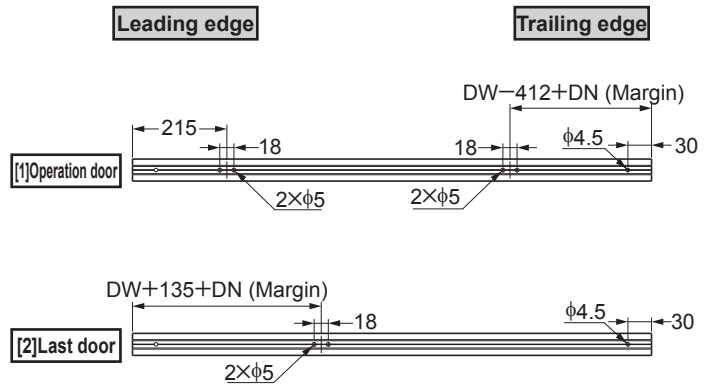

### <FD30SP: 3 doors synchronized>

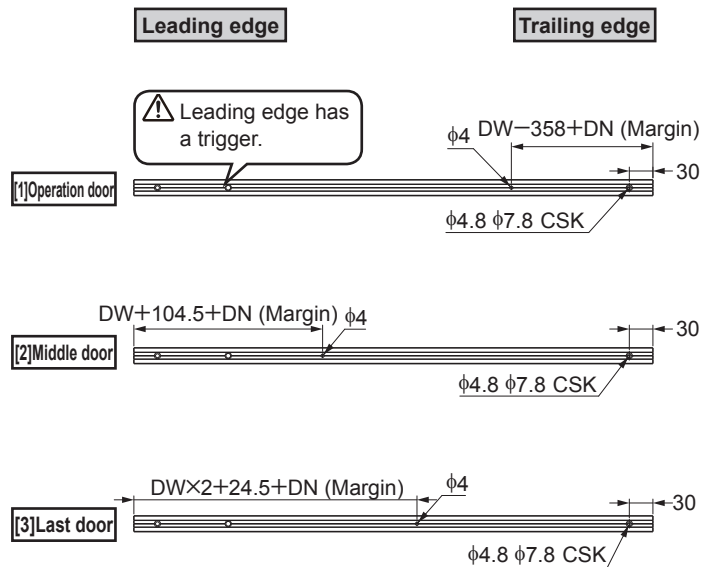

### <FD50SP: 3 doors synchronized>

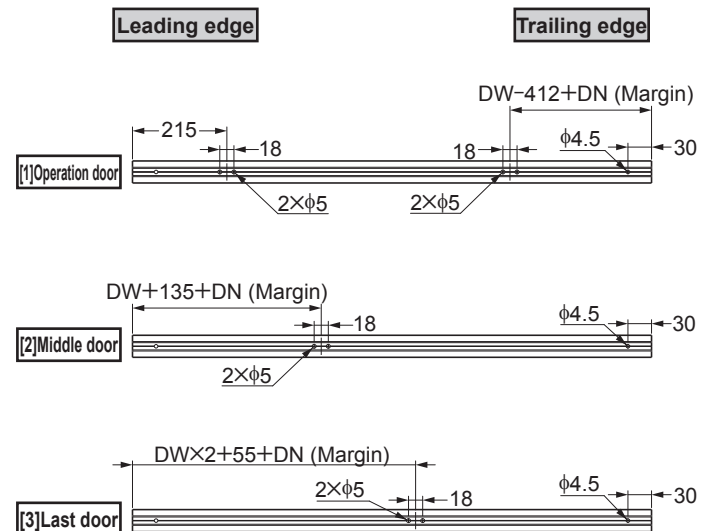

### 3 Assembly of Door Guide

Turn the direction of the guide block according to door thickness.

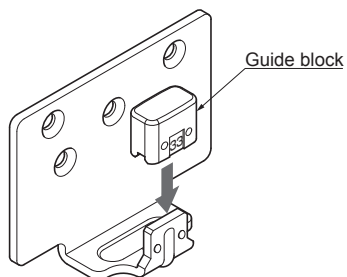

Door thickness	Marking
30-34	33
35-38	36

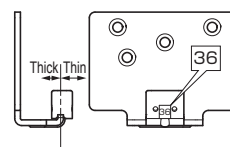
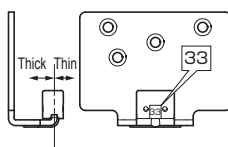

### 4 Mounting Parts on Door

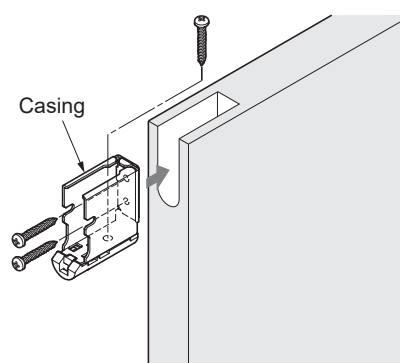
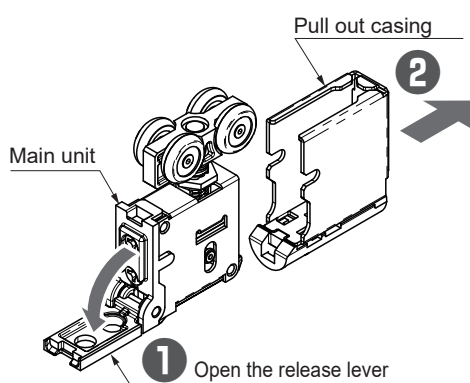

# 5 Parts Assembly on Doors △ For an opposite handed door, assemble the parts in the mirror opposite position.

## <2 doors synchronized>

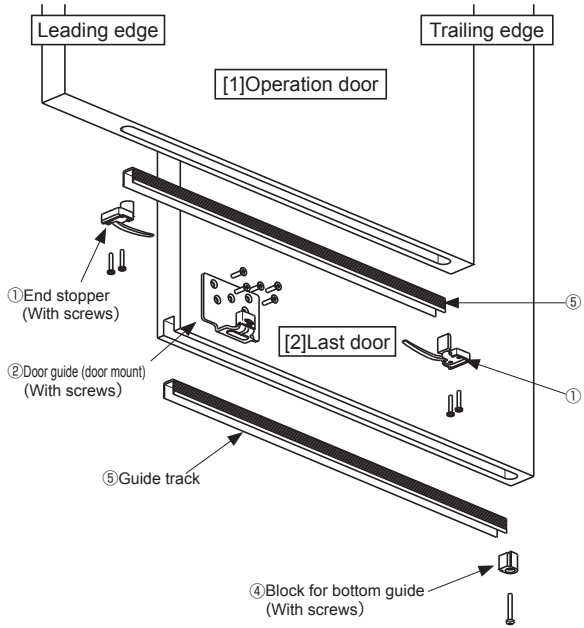

## <3 doors synchronized>

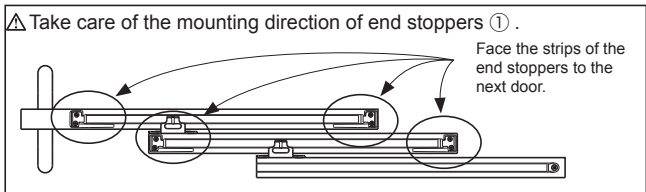
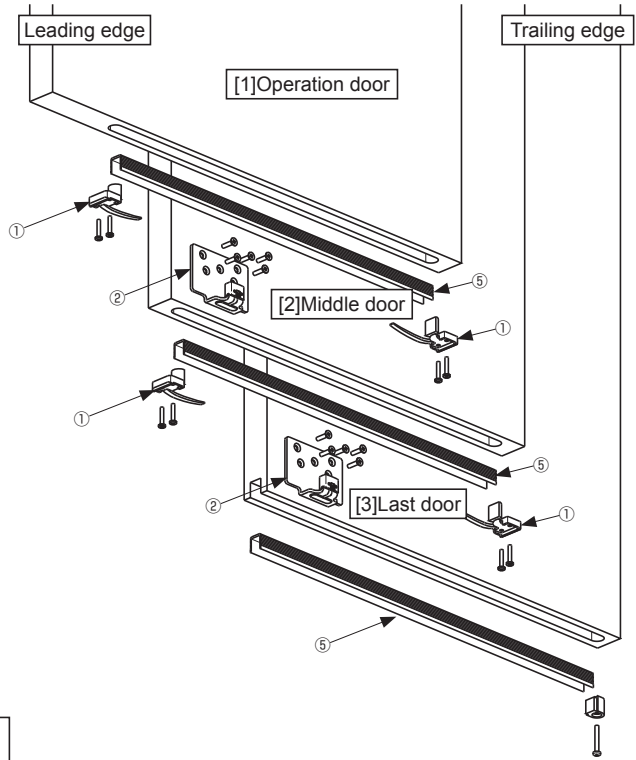

△ Please prepare the screws for the guide tracks for FD50.  
Countersunk head tapping screw 4x20

### <2 doors: Mounting parts on operation door>

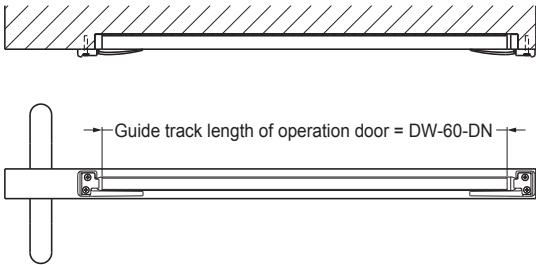

### <3 doors: Mounting parts on operation door>

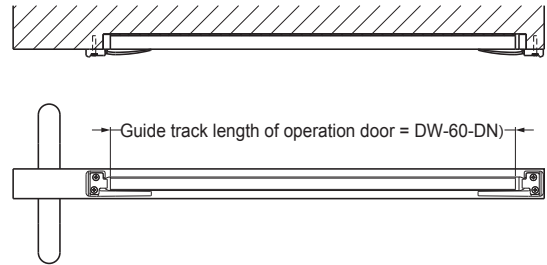

### <2 doors: Mounting parts on last door>

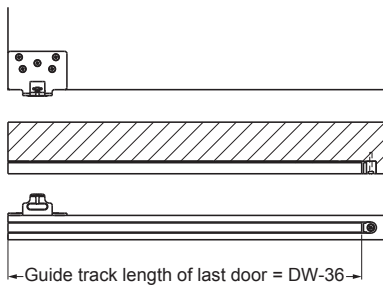

### <3 doors: Mounting parts on middle door>

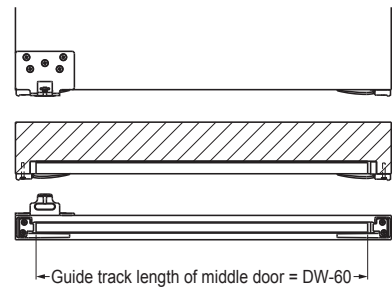

### <3 doors: Mounting parts on last door>

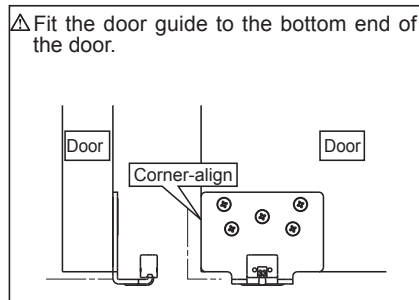
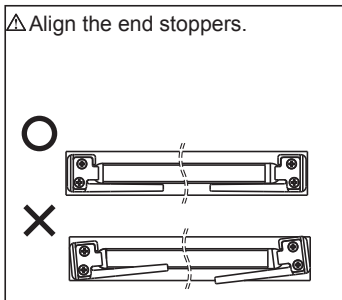
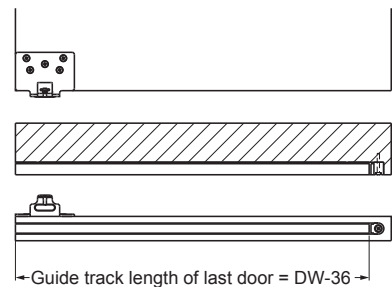



## 6 Verification Before Installing Soft Closer

**Caution**  
Without verification the self closing feature may fail.

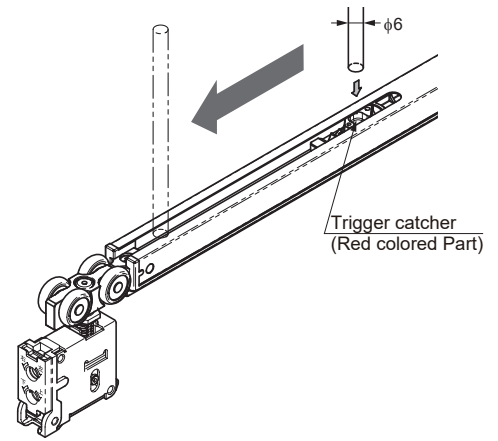
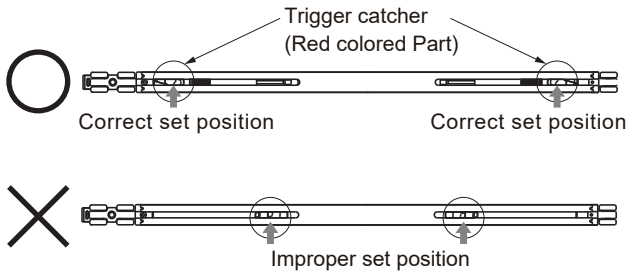

If the position is wrong, pull back the trigger catcher to the correct position using a 6mm

## 7 Inserting Parts into Upper Tracks

Insert the parts in the same order as shown in the figure. Tape around rollers and upper track to prevent inserted parts from falling.

⚠ Remove any dirt or aluminum chips from the track.

⚠ For FD30EX, please prepare the screws; Countersunk head tapping screw 3.5 × 20.

<2 doors synchronized>

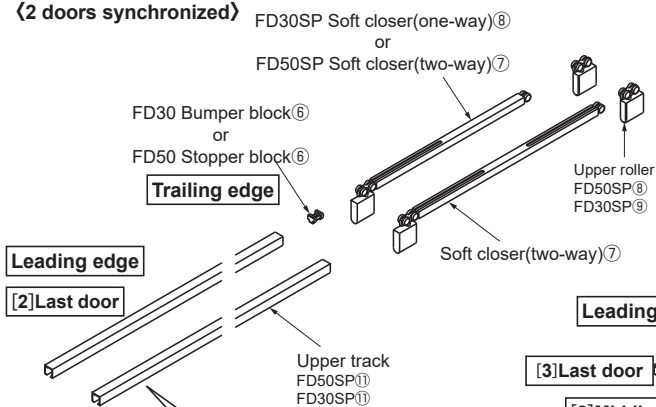

⚠ Verify the direction of tracks.  
FD30: Trigger is attached to the leading edge.  
FD50: Leading edge has two holes 215 mm from the end.

<3 doors synchronized>

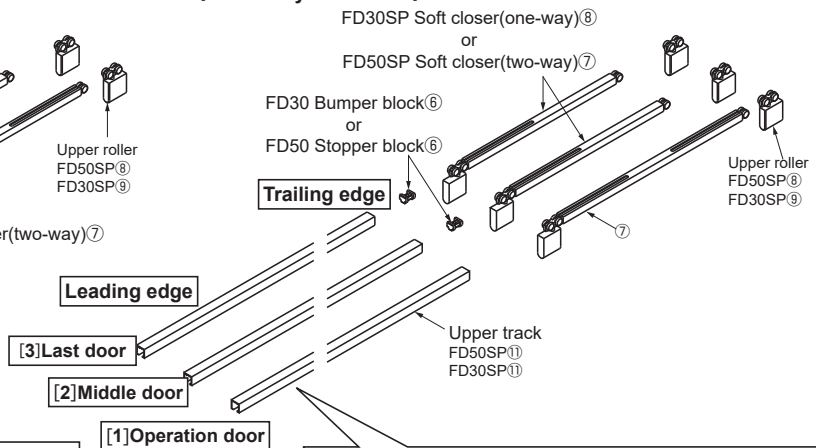

⚠ Verify the direction of tracks.  
FD30: Trigger is attached to the leading edge.  
FD50: Leading edge has two holes 215 mm from the end.

## 8 Fastening Additional Triggers

Fix trigger to the hole made during procedure 2.

**Caution**  
Fasten the triggers vertically and firmly.

<FD30SP 2 doors synchronized>

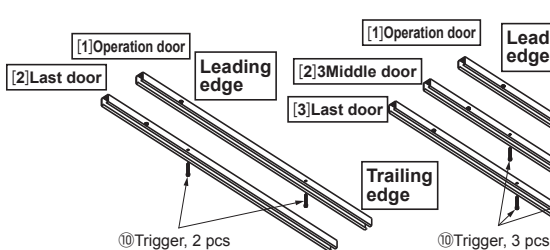

<FD30SP 3 doors synchronized>

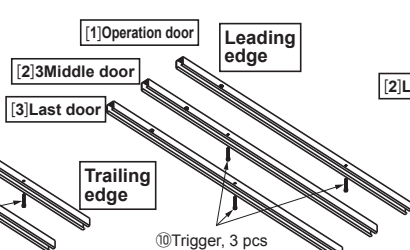

<FD50SP 2 doors synchronized>

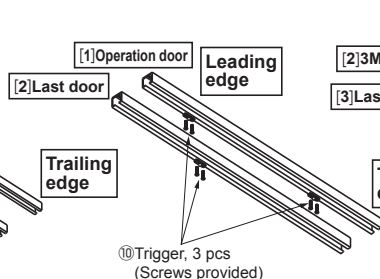

<FD50SP 3 doors synchronized>

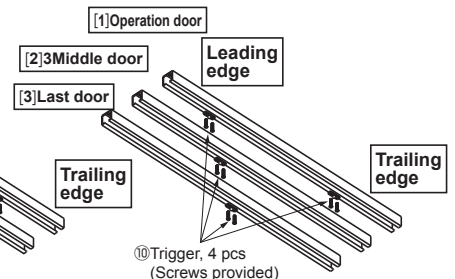

## 9 Mounting Door Guides

### < 2 doors synchronized >

Mount the guide to the bottom of last door.

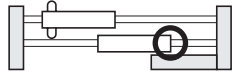

### < 3 doors synchronized >

Mount the guide to the bottom of last door.

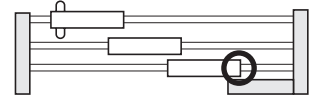

#### [1] Door guide ③

① Fasten the base plate with provided screws.

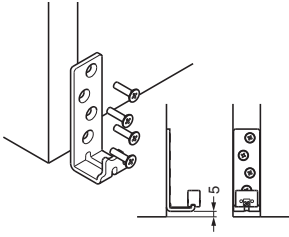

② Insert the guide block according to the table and illustration right.

Door thickness	Marking
30 ~ 34	33
35 ~ 38	36

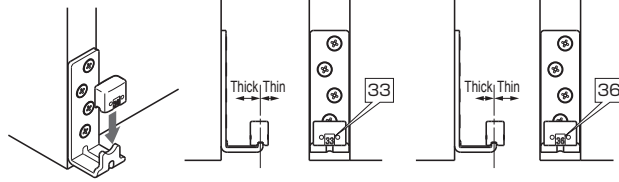

#### [2] Floor guide ⑭ (Optional parts)

Position floor guide just below the center of upper track.

Position the floor guide so that it stays under the door when it is opened or closed.

#### FD30SP

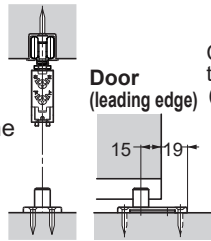

Door (leading edge)

15 19

Countersunk head tapping screw 3.5 × 30 (included in ⑭)

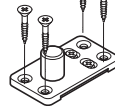

#### FD50SP

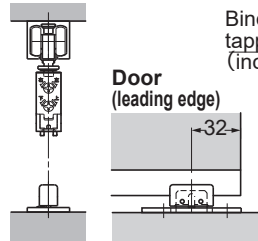

Door (leading edge)

32

Binding head tapping screw 4 × 16 (included in ⑬)

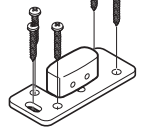

## 10 Hanging Door

#### [1] Order of hanging

Hang the doors in order from ① to ③.

#### < 2 doors synchronized >

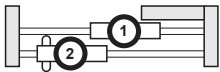

#### < 3 doors synchronized >

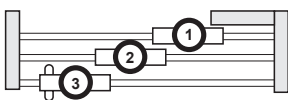

#### [2] Hanging

Put a 13 mm support under the door. While holding the door, insert the guide into the groove under the door.

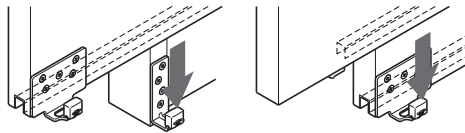

#### [3] Insert the upper roller into the casing

until a click sound is heard.

Verify that the main unit is not dislocated from the casing, for both door head and door tail sides.

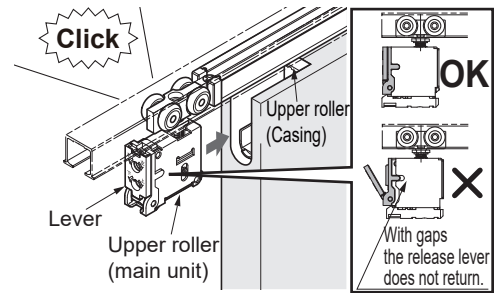

## 11 Mounting Bottom Guide (Optional parts)

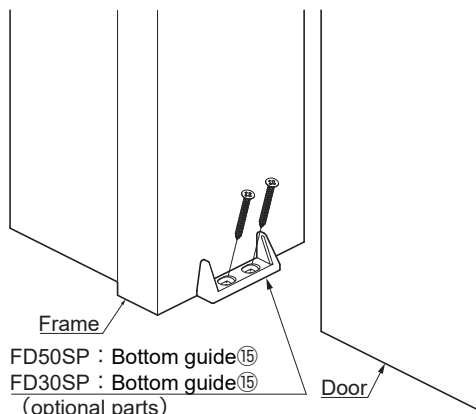

Frame

FD50SP : Bottom guide ⑮

FD30SP : Bottom guide ⑮

(optional parts)

Door

Fit the bottom guide to the closed door, then fasten it with provided screws.

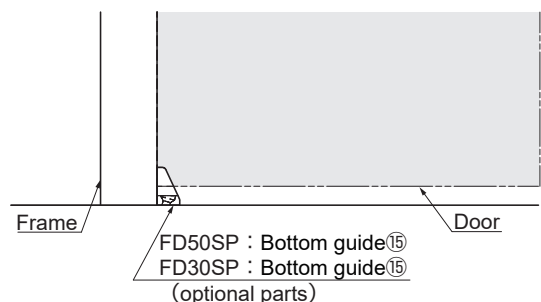

Frame

FD50SP : Bottom guide ⑮

FD30SP : Bottom guide ⑮

(optional parts)

Door

## 12 Verification of Soft Closer Operation

- [1] Remove the 13 mm support from under the door.
- [2] Close the door slowly and check that the soft closer works correctly.
- [3] For the operation door, carry out similar verification for the door trailing edge.
- [4] Please refer to the "Troubleshooting" section when the soft closer does not work correctly.
- [5] If necessary, adjust position of bumper block and stopper block in the track so that the position is realized as shown in "Installation Drawing". Then fix them by tightening them with screws.

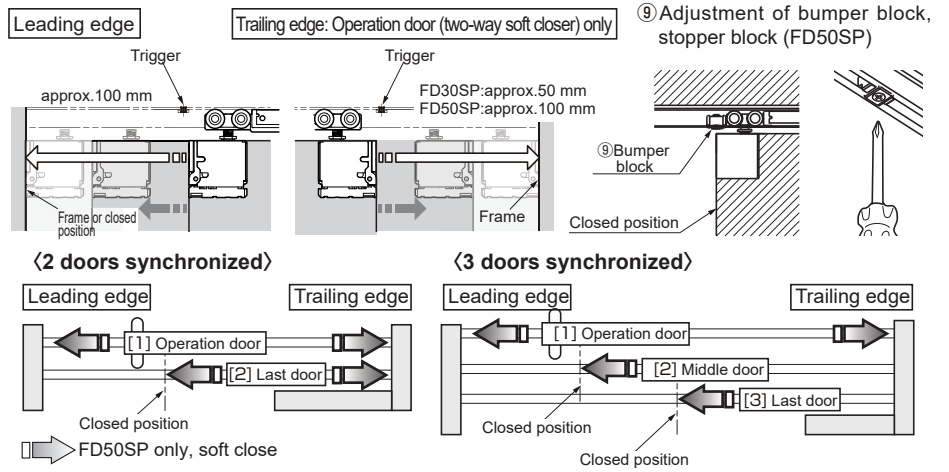

## 13 Adjusting the Door Position

- [1] Order: [1] Operation door, [2] Middle door, [3] Last door
- [2] [1]: Adjust the door so that it is parallel to the upper track with 13 mm of clearance between the door and floor.
- [3] [2], [3]: Adjust the door so that the clearance between the door bottom and door guide will be 5 mm.

- ⚠ The adjustment of the door should be done with the jump prevention nut loosened (see section 14).
- ⊘ Do not turn adjustment screw beyond adjustment range.
- ⊘ Do not use electric screw driver.

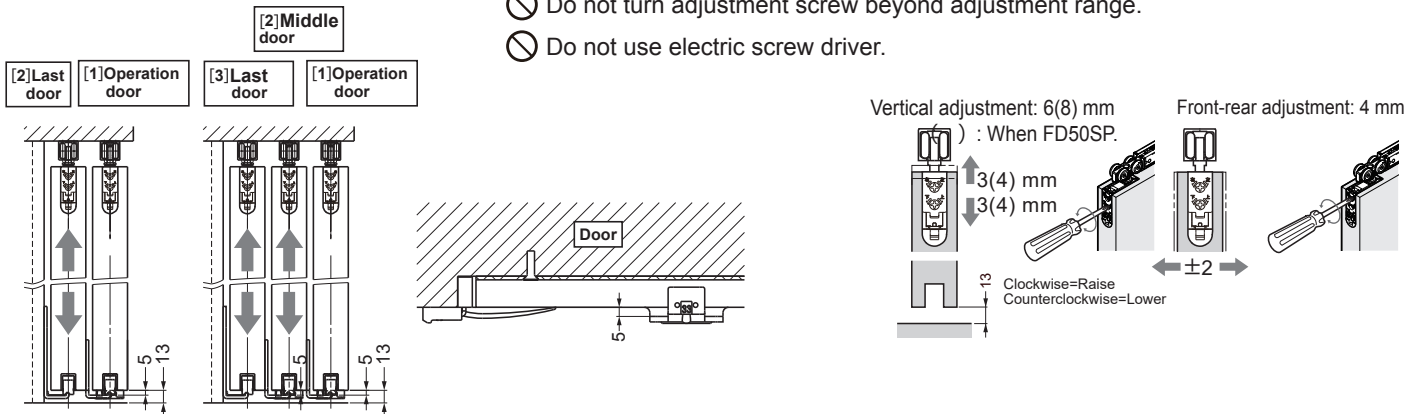

After finishing vertical adjustment of door, repeat confirmation of sliding door closer operation (section 12). If the door is not closed completely, the clearance between the door bottom and door guide may be less than 5 mm. In this case, lower the middle door and the last door slightly.

## 14 Fastening the Jump Prevention Nut

The jump prevention nut is on the hanger bolt of the recessed roller. Tighten the nut with the provided spanner until it contacts the soft closer.

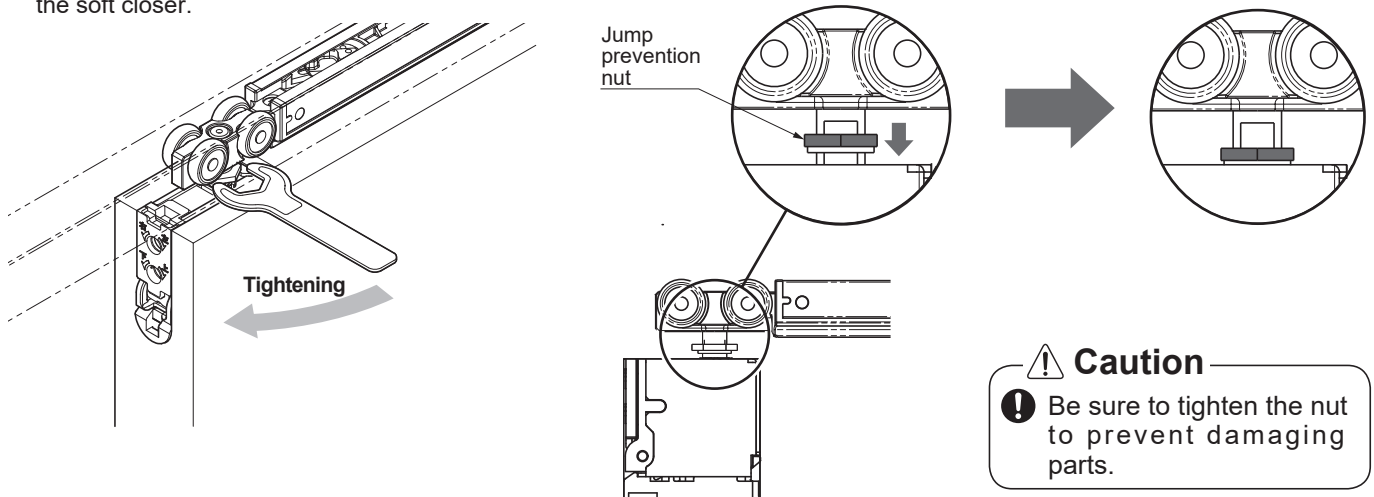

## APPENDIX 1 How to Remove Door

- Use a 13 mm support under the door.
- Pull out the spacer cap.
- Then pull out the upper roller main unit from the door while lower the lever.  
If it is difficult to install or detach the roller, loosen the nut as shown in the illustration.
- It will be easier if you slide the hanger bolt with a spanner wrench.

### ⚠ Caution

- ❗ Be careful not to let the door fall.

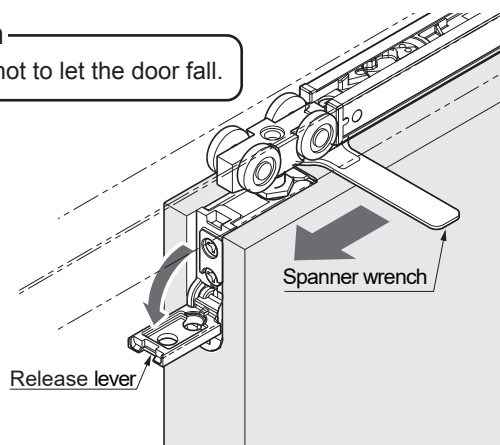

## APPENDIX 2 When Vertical Frame is not used

When a vertical frame is not used, be sure to use the door stopper (floor).

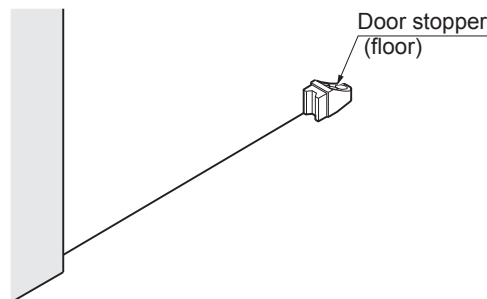

### PERIODICAL INSPECTION

- Clean inside of track.
- Check upper and lower gaps between the door and frame. If necessary, adjust the gaps.

## TROUBLESHOOTING ( ) : When FD50SP.

Trouble	Check Point	Solution
Door stops during soft closing	Check if door bottom contacts the floor or floor guide.	Verify that the track mounting screws are not loosened. Then, adjust the door height such that the clearance between the door bottom and floor is 10 ~ 16 (9 ~ 17) mm.
	Check if upper track is set horizontally.	Using a level gauge, reset the upper track horizontally.
	Check if mohair seal is installed.	Reduce the friction between the mohair seal and door.
The door doesn't close softly	Check if trigger is installed.	Install trigger to specified position.
	Check if door is closed by excessive force.	Do not close door by excessive force as it may damage the soft closer.
	The position of the trigger catcher in page 9 section 7 may become dislocated. (It is hidden as installed in upper track.)	Remove the door and the upper track, then check the status of the trigger catcher in section 7.
Abnormal noise during operation	Check if door bottom contacts the floor or floor guide.	Verify that the track mounting screws are not loosened. Then, adjust the door height such that the clearance between the door bottom and floor is 10 ~ 16 (9 ~ 17) mm.
	Check if door touches adjacent parts.	Adjust the door depth position to avoid contact with other objects or adjust the position of floor guide.
	Check track rollers for aluminum dust.	Remove the track, then pull out and clean the roller.
	Check the track mounting screws for looseness.	Retighten the screws to free the roller.
Heavy door operation	Check if door bottom contacts the floor or floor guide.	Verify that the track mounting screws are not loosened. Then, adjust the door height such that the clearance between the door bottom and floor is 10 ~ 16 (9 ~ 17) mm.
	Check if door touches adjacent parts.	Adjust the door depth position to avoid contact with other objects or adjust the position of floor guide.
Door does not move.	Check the track retaining screws for looseness.	Retighten screws to free the roller.
Door starts to move.	Check if the upper track is set horizontally.	Using a level gauge, reset the upper track horizontally.

**SUGATSUNE KOGYO CO., LTD.**  
Tokyo, JAPAN  
Phone: +81 3 3866 2260  
E-mail: export@sugatsune.co.jp

**SUGATSUNE KOGYO (UK) LIMITED**  
Reading, UK  
Phone: +44 1189 272 955  
E-mail: sales@sugatsune.co.uk

**SUGATSUNE EUROPE GmbH**  
Düsseldorf, GERMANY  
Phone: +49 211 53812 900  
E-mail: sales@sugatsune.eu

**SUGATSUNE AMERICA, INC.**  
California, USA  
Phone: +1 310 329 6373  
E-mail: sales@sugatsune.com

**Chicago, USA**  
Phone: +1 630 317 7072  
E-mail: sales@sugatsune.com

**SUGATSUNE CANADA, INC.**  
Montreal, CANADA  
Phone: +1 514 312 5267  
E-mail: support@sugatsune.ca

**SUGATSUNE SHANGHAI CO., LTD.**  
Shanghai, CHINA  
Phone: +86 21 3632 1858  
E-mail: lamp@sugatsune.com.cn

**Guangzhou, CHINA**  
Phone: +86 20 6639 3554  
E-mail: lamp@sugatsune.com.cn

**SUGATSUNE KOREA CO., LTD.**  
Incheon, KOREA  
Phone: +82 32 220 0603  
E-mail: sales@sugatsune-korea.co.kr

**SUGATSUNE KOGYO INDIA PRIVATE LIMITED**  
Mumbai, INDIA  
Phone: +91 9867299597  
E-mail: sales@sugatsune.in  
**Delhi, INDIA**  
Phone: +91 9867299597  
+91 11 45093636  
E-mail: sales@sugatsune.in