

# LAMP® SOFT DOWN STAY SDS-201 INSTALLATION INSTRUCTION



- Please read this instruction sheet carefully for proper installation and operation. Incorrect installation and improper use of the product may damage the unit or cause injury.
- This stay is designed for furniture or lightweight door and is equipped with a damping function.
- Sugatsune guarantees the quality of this product as for all its parts. It cannot however guarantee the final assembly as a whole.
- This product was manufactured and delivered with our utmost care. Should you however find any defect, please contact your dealer immediately.
- Sugatsune warrants that this product is free from defect for a period of one (1) year from the date of delivery.
- Sugatsune liability is limited to the replacement of this product by a similar one free of defect. In no case does this extend to the replacement of the installation or the cabinet as a whole.
- Please keep these instructions at hand for future use.
- Sugatsune cannot be held liable for any damage or injury caused by improper use or one different than the one this product was designed for.

**⚠ CAUTIONS** Any failure to observe the following precautions may result in personal injury or damage to the cabinet

- Ⓛ Make sure that installation position and specifications are followed. Unsuitable installation position may damage the mechanism when in case two stays are used together.
- Ⓛ Make sure that the arm of the stay is parallel with the side panel of the cabinet.
- Ⓛ Please avoid forced opening beyond the opening angle, and using excessive force while closing the door.
- Ⓛ This product is designed to operate at room temperatures between 0°C to 40°C (32F-104F).
- Ⓛ This product has a spring at the elbow section. Please be careful not to get your fingers caught in elbow section while you are handling the unit.
- Ⓛ Performance of hardware will be affected by unique factors in each application. Hardware must be tested in intended application to confirm the function.
- Ⓛ It is necessary to periodically check the fixing screws for loosening. Tighten the loosened screws as required.
- Ⓛ Do not force the door to close faster. It can cause damage to the product or hinge(s).
- Ⓛ Please make sure to check the operation after installation.

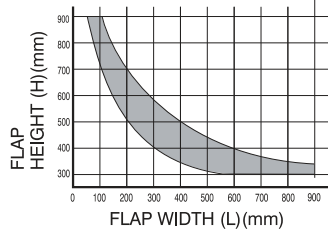
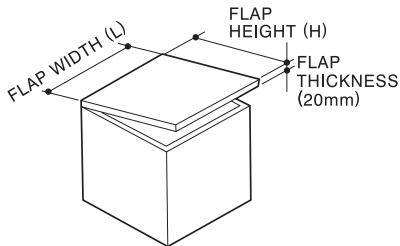

## THE DIMENSION OF THE FLAP

SOFT DOWN STAY must be used taking the size of the flap into consideration. The graph indicates the usable range when using one SDS stay. When using two stays, the width of flap can be twice as large, if the height remains unchanged. (Note) The graph shown to the left is in case of a general wooden flap of 20mm thick (specific gravity approx. 0.5)

- In case of lighter or heavier flap doors that do not fit within the above specified range, please contact our sales staff.

Code No.	Suitable Screw on mounting plate	Suitable Screw on arm fixing plate
SDS-201	φ 3.5×4	φ 3.5×2

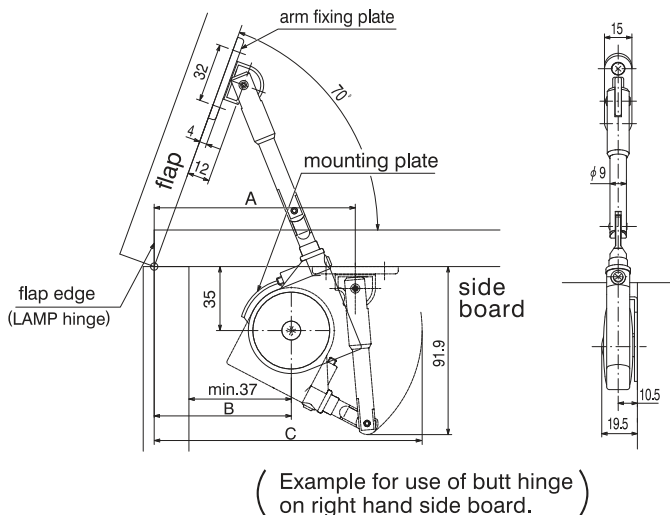

## ● PLATE POSITION FOR INSTALLATION

Depending on the type of the hinges used, the position of the mounting plate and arm fixing plate should be fixed as indicated below. In this case where LAMP hinge (230-26/19T) is used, the distance for A/B/C is measured from the flap edge.

	A	B	C
LAMP hinge (230-26/19T)	109	74	146

(1 inch ≒ 25.4mm)

When other types of hinges are used, please contact our sales staff.

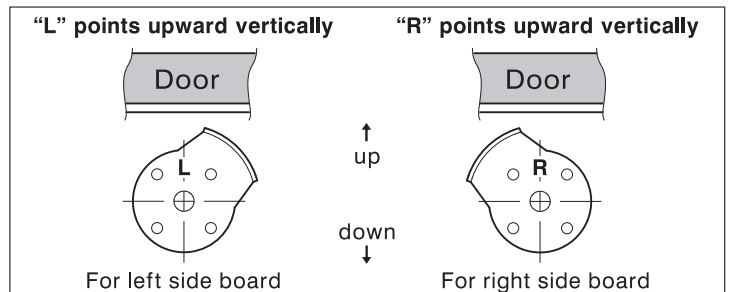

## ● HOW TO INSTALL

Install the mounting plate and arm fixing plate with the enclosed wood screws at the designated places.

- ① Insert the "key" of the cam of arm-tip into the key hole of the fixing plate. The main body must be placed at 90 degrees angle against the fixing plate.

- ② Turn the main body 90 degrees and insert the pin of the mounting plate in the hole of the main body.
  - ※ While turning the main body ensure to hold the arm along with the main body.
- ③ Fix the main body with bind screw provided.

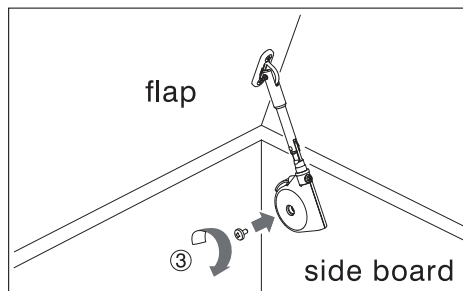
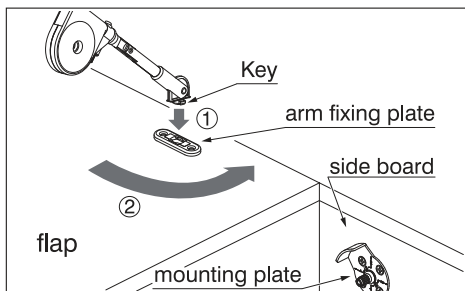

## ● ADJUSTMENT

At maximum door opening angle, make the adjustment of arm-fold in straight by adjustable screw of main body on stopper-pin.

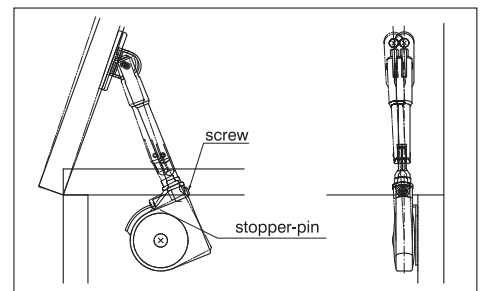

**SUGATSUNE KOGYO CO.,LTD**  
Tokyo, JAPAN  
Phone: +81 (0)3 3866 2260 E-mail:export@sugatsune.co.jp

**SUGATSUNE KOGYO (UK) LTD**  
Reading, UK  
Phone: +44 118 9272 955 E-mail:sales@sugatsune.co.uk

**SUGATSUNE EUROPE GmbH**  
Düsseldorf, GERMANY  
Phone: +49 211 53812900 E-mail:sales@sugatsune.eu

**SUGATSUNE SHANGHAI Co., LTD**  
Shanghai, CHINA  
Phone: +86 21 3632 1858 E-mail:lamp@sugatsune.com.cn

**Guangzhou, CHINA**  
Phone: +86 20 6639 3552 E-mail:lamp@sugatsune.com.cn

**SUGATSUNE KOGYO INDIA PRIVATE LIMITED**  
Mumbai, INDIA  
Phone: +91 22 28314490/91 E-mail:sales@sugatsune.in

**SUGATSUNE AMERICA, INC**  
California, USA  
Phone: +1 310 329 6373 E-mail:sales@sugatsune.com

**Chicago, USA**  
Phone: +1 312 461 1081 E-mail:chicagoshowroom@sugatsune.com.

**SUGATSUNE CANADA, INC.**  
Phone: +1 514 312 5267 E-mail:support@sugatsune.ca